

Two horizontal blue bars, one dark blue and one light blue, positioned above the main title.

# Neonate Bilirubin Phototherapy Equipment XHZ-90S

---

Product Training

A background image of a modern glass building with a grid pattern, partially obscured by a light blue overlay.

# CONTENTS



01

Product Introduction

02

Specification and Configuration

03

Operation

04

Cleaning and Maintenance

05

Troubleshooting

# 01

PART ONE

---

## Product Introduction



# Product Introduction



The Neonate Bilirubin Phototherapy Equipment XHZ-90S irradiates the visible light with the primary radiation spectrum ranging from 400 nm to 550 nm to reduce the bilirubin concentration of neonate.

# Product Introduction



- Intensive blue light irradiation, effectively reduce jaundice

## **Stronger light source**

Using SMD LEDs, the total bilirubin irradiance can reach more than  $75\mu\text{W}/\text{cm}^2/\text{nm}$ , in line with the American Academy of Pediatrics (AAP) for the guidance of intense light therapy equipment requirements, which can effectively reduce jaundice and shorten the treatment time.

## **Longer service life**

Service life of LED  $\geq 50000$  hours, effectively reducing energy consumption.

## **Better wavelength**

The irradiation wavelength is 400~550nm, which can achieve the best bilirubin absorption efficiency and effectively treat neonatal jaundice.



# Product Introduction



- Large touch screen, high-definition display

## LCD touch screen

Independent 4.3-inch color LCD screen, full touch visual operation with two timing modes of count down and count up.

PWM control is used to realize the infinite adjustment of blue light brightness.

## Total blue light timer

It is convenient for medical staff to change the light source in time, so as to ensure the effect of phototherapy.



# Product Introduction



- **Humanized design, flexible application**

### **Easy to adjust**

The height of the whole machine can be adjusted freely, and the tilt angle of the irradiation light box can also be adjusted, providing medical staff with a variety of clinical treatment options.

### **Stable structure**

Casters can be locked to ensure the stability during jaundice treatment.

### **Flexible matching**

It can be used with infant care equipment to provide better jaundice treatment effect, such as infant incubator.



# Product Introduction

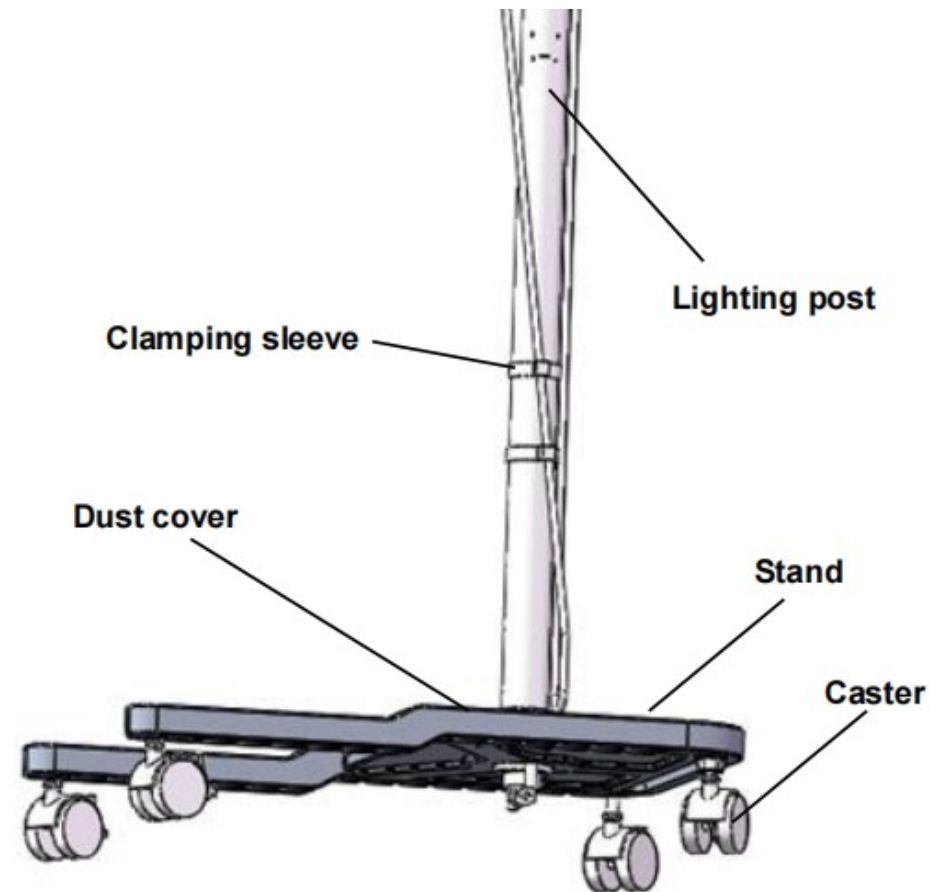
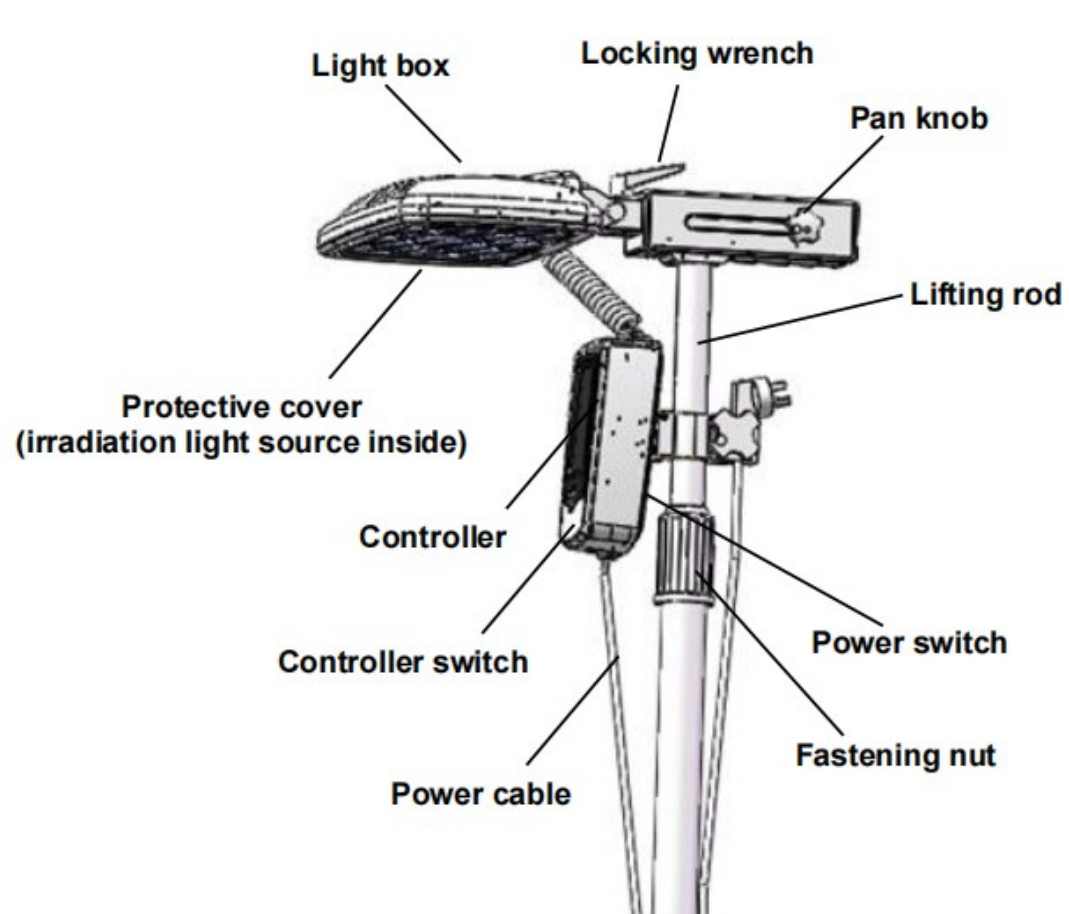

# 02

PART TWO

---

## Specification and Configuration



# Specification and Configuration

- ◆ Phototherapy light source: blue LED
- ◆ Service life of light source: not less than 50000 hours
- ◆ Built-in timer range: 0~99999.9 hours
- ◆ Effective illumination area: 40 cm × 30 cm
- ◆ Total irradiance within the effective surface area:  $\geq 75 \mu\text{W}/\text{cm}^2/\text{nm}$
- ◆ Average value of total bilirubin irradiance:  $\geq 50 \mu\text{W}/\text{cm}^2/\text{nm}$
- ◆ Maximum total bilirubin irradiance within the effective surface area: 83  $\mu\text{W}/\text{cm}^2/\text{nm}$
- ◆ Uniformity of the total irradiance for bilirubin on effective irradiated area of mattress:  $\leq 0.4$
- ◆ Noise level:  $\leq 50\text{dB(A)}$
- ◆ Blue light output strength setting range: 0~100%
- ◆ Irradiation distance: 40cm
  
- ◆ Standard configuration:
  - ◆ Irradiation light box, controller, mobile stand.



# 03

## PART THREE

---

# Operation



- **Interface introduction**



The screenshot shows a control interface for a light source. At the top, a 'Clockwise' button is highlighted. Below it, a large digital display shows '0.0'. Underneath the display is a 'Setting [ ] h' label. The interface features two main sections: 'Total working time' showing '00001.0 h' and 'Blue-ray output intensity' with a slider set to '50 %'. At the bottom, there are two buttons: 'Start/Suspend' and 'Menu'. Red lines connect these interface elements to their respective labels on the left and right.

Timing mode area

Current working time of the light source

Preset countdown time area

Total working time area

Blue light output strength area

Start/Suspend button

Menu



# Operation

- **Interface introduction**

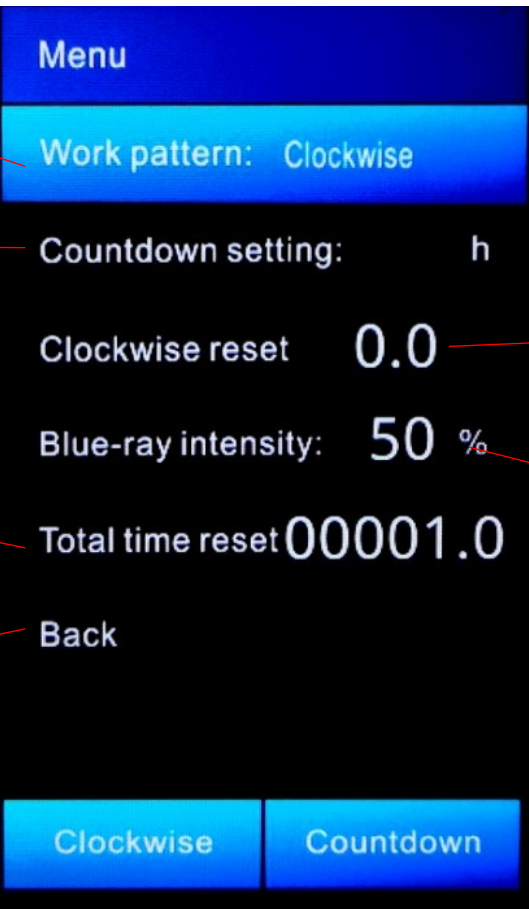

The screenshot shows a menu interface with the following elements and annotations:

- Working mode (Count-up or Countdown):** Points to the "Work pattern: Clockwise" option.
- Countdown time setting (applicable only in Countdown mode):** Points to the "Countdown setting: h" field.
- Clear the total working time:** Points to the "Total time reset 00001.0" field.
- Return:** Points to the "Back" button.
- Clear the count-up time:** Points to the "Clockwise reset 0.0" field.
- Blue light output strength:** Points to the "Blue-ray intensity: 50 %" field.

At the bottom of the screen, there are two buttons: "Clockwise" and "Countdown".



## ● Preparations before treatment

- ◆ Clean and disinfect the bilirubin equipment.
- ◆ Light box horizontal adjustment: Loosen the pan knob to horizontally move the light box to the desired position.
- ◆ Light box tilt angle adjustment: Loosen the locking wrench to lift up the light box and adjust it to the appropriate angle. Then, rotate the locking wrench by 90 degrees to lock the light box.
- ◆ Controller height adjustment: Loosen the knob and move the hoop on the desired height, then fasten the knob.
- ◆ Light box height adjustment: Loosen the knob and move the hoop on the desired height, then fasten the knob, to adjust the height of the phototherapy equipment until the light box is 40 cm away from the effective area.

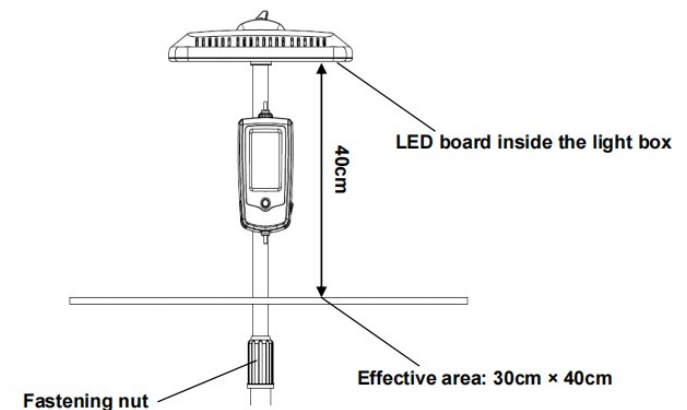
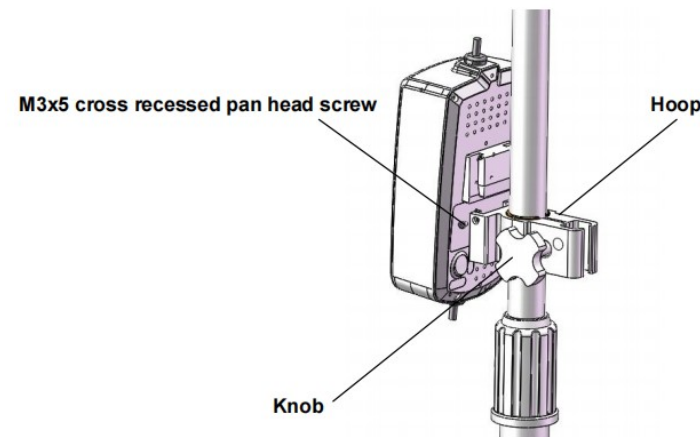
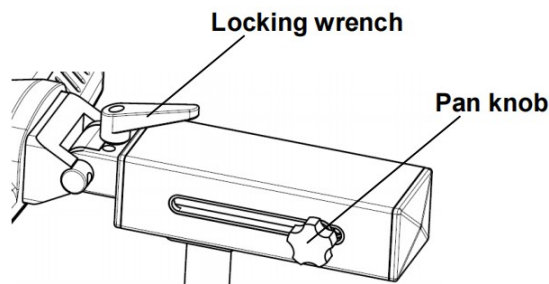

- **During the treatment**

- ◆ Lay the naked patient in the effective area.
- ◆ Put an eye mask on the patient and cover the patient's genitals with a diaper or other similar items.
- ◆ Connect to the equipment power supply, turn on the power switch of the bilirubin equipment, turn on the controller switch on the controller, and press the Menu button. Then, select the working mode and blue light output intensity.
- ◆ After setting the blue light intensity and working mode, adjust the irradiation distance properly, and press the Start/Pause button to start phototherapy.
- ◆ Leave the radiation area promptly to avoid long-time exposure to optical radiation. If you need to perform operations on the bilirubin equipment again or take care of or inspect the patient, do not look straight into the light source with naked eyes or through optical instruments.
- ◆ Turn off the controller power switch and main power switch, and disconnect the power cable after operation.



# 04

PART FOUR

---

## Cleaning and Maintenance



# Cleaning and Maintenance



- ◆ When you use the bilirubin equipment for the first time or after you use it continuously for one week, clean and disinfect the bilirubin equipment thoroughly.
- ◆ **Warning:** Before cleaning or maintaining the device, disconnect the device from its power supply and turn off all power switches.
- ◆ Use a neutral detergent or sanitizer to thoroughly clean all surfaces of the bilirubin equipment, including all corners and recesses (It is recommended to wash more than three times), and then dry them with a clean pure cotton cloth or tissues.
- ◆ **NOTE:** To prevent cracks in the plexiglass protective cover, do not use ethanol, acetone, or other organic solvents, and do not expose the cover directly to ultra-violet rays.
- ◆ **CAUTION:** During cleaning, prevent the liquid from flowing into the bilirubin equipment through the heat dissipation vent.

# Cleaning and Maintenance

- **Maintain the light source**

Trained professionals with sufficient knowledge and experience are required to measure the total bilirubin irradiance of the bilirubin equipment at least once a year. Ensure that the identification certificate of the irradiator is valid. Draw the effective area (40cm × 30cm) in the irradiation area. Divide the effective area into 10mm × 10mm subareas. Use an irradiator to measure the total bilirubin irradiance in each subarea (ensure that the sensitivity matches the "Calibration curve of the measuring device"), and determine the maximum value. Then, replace the light source if the maximum value has a deviation of 25% from the specified value.

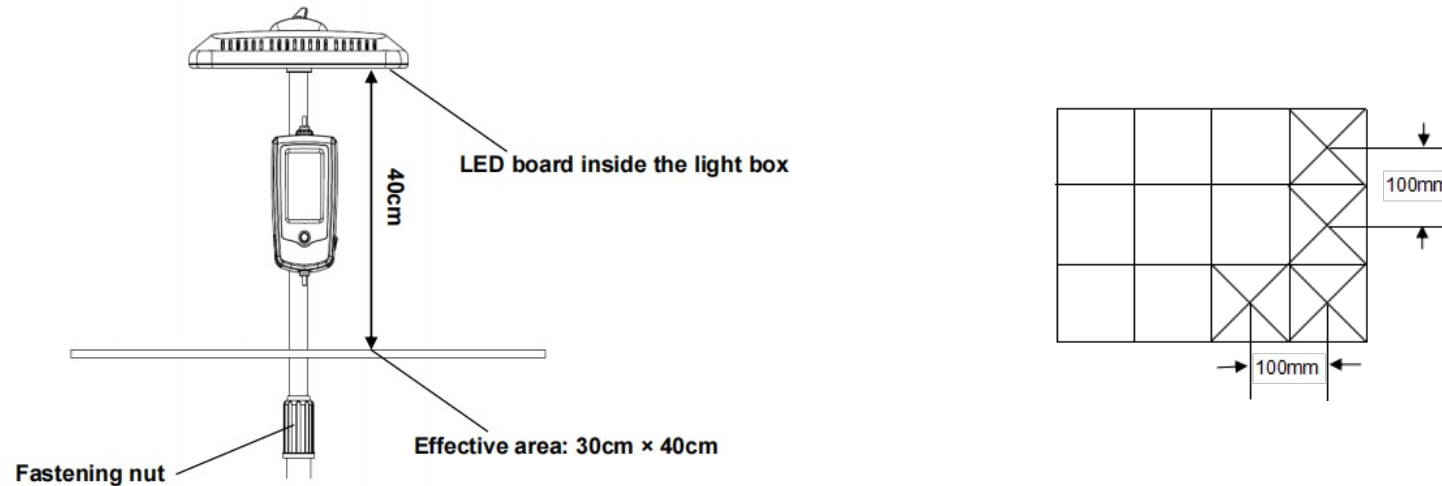

# Cleaning and Maintenance

- **Replace the LED board**

Step 1: Remove the screw masks from the light box enclosure and loosen the fastening bolts on the light box enclosure.

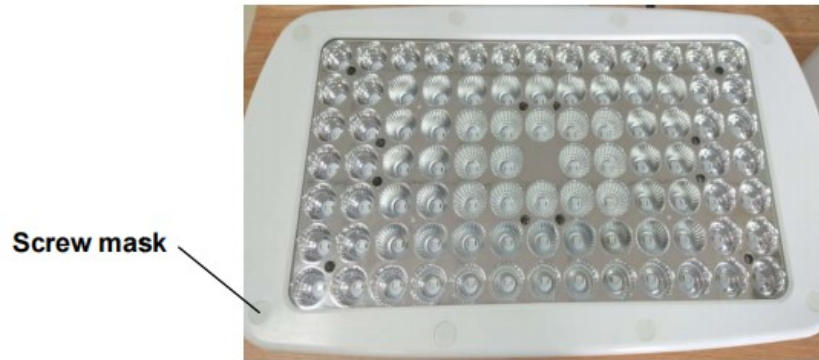

Step 2: Disconnect the connection cable from the LED board and loosen the four fastening bolts on the LED lining board to replace the LED board.



# Cleaning and Maintenance

- **Replace the switch-mode power supply and the controller mainboard**

Step 1: Loosen the four fastening bolts on the back of the controller and take off the backplate.

Step 2: Disconnect all connection cables from the switch-mode power supply and controller mainboard. After taking out the switch-mode power supply assembly and controller mainboard assembly, disconnect all connection cables from the controller display assembly. Then loosen the four screws on the controller display and replace the controller display.



Fastening bolt

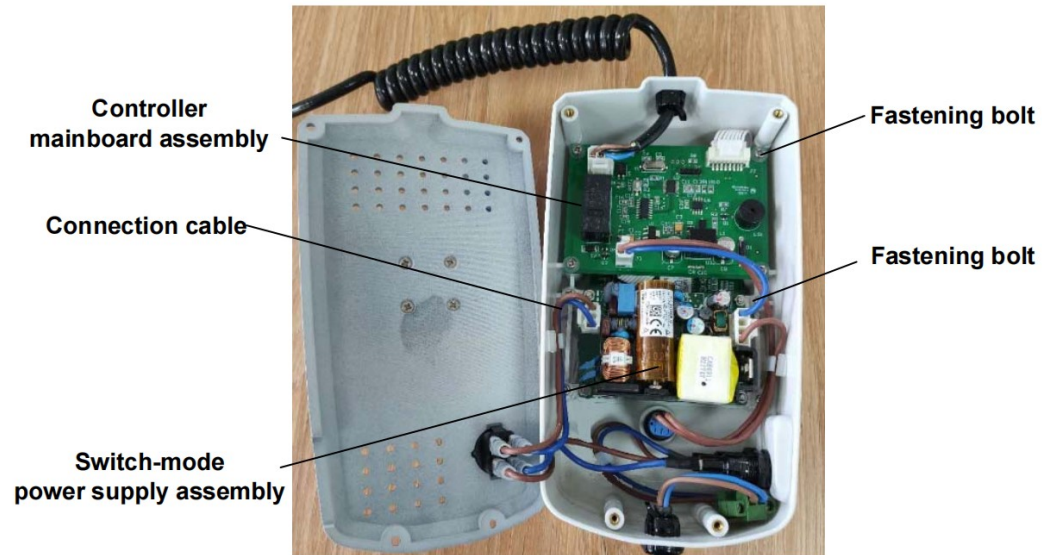

Controller mainboard assembly

Connection cable

Switch-mode power supply assembly

Fastening bolt

Fastening bolt



# Cleaning and Maintenance

- **Replace the controller display**

Proceed from the step of replacing the switch-mode power supply and controller mainboard. After taking out the switch-mode power supply assembly and controller mainboard assembly, disconnect all connection cables from the controller display assembly. Then loosen the four screws on the controller display and replace the controller display.

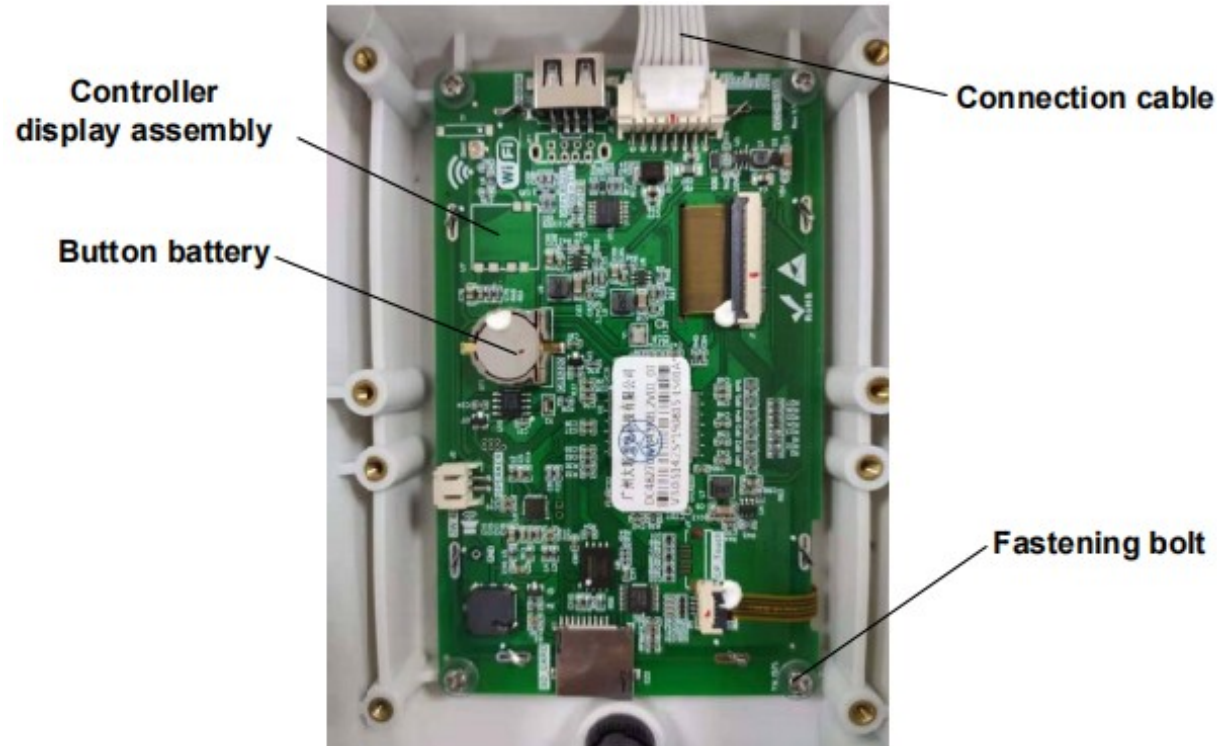

# Cleaning and Maintenance

## ◆ Replace the fuse tubes

Loosen the fuse tube cover plate and replace two T1.6AL/250 V fuse tubes.



Fuse tube base



# 05

PART FIVE

---

## Troubleshooting



# Troubleshooting



Symptom	Possible Cause	Solution
All light sources cannot light up.	Power failure occurs.	Turn off the power switch
	The power cable is disconnected.	Connect the power cable.
	The power switch is turned off.	Turn on the power switch
	The fuse tube is damaged.	Replace the fuse tube.